

OS4 – Industrial Glass Optical Liquid Level Switch

The OS4 is a single point liquid level switch that can operate in high pressure, high temperature, and aggressive environments due to its stainless steel and glass construction. In addition to offering industrial supply voltages and outputs that can directly drive loads. The sensor can detect the presence or absence of almost any liquid, oil or water based, and can be configured to output a high or low signal in either a wet or dry state. Options for connecting to inductive loads or digital interfaces are also available. This single point liquid level switch can operate up to 8700 psi with housing threads suitable for external sensor mounting and for use in operating temperatures up to 125°C.

OS4

This industrial optical sensor is capable of driving high power loads and able to sink/source up to 1A. Designed for high power signaling of liquid presence/absence of liquid or operation at a high voltage, in high temperature and high pressure environments. Stainless steel, corrosion resistant housing and glass sensing tip allows the sensor to be used in harsh chemical conditions.

Output Sink / Source Current	Max Switching Current	Max Switching Voltage	Operating Temp	Max Pressure
1 A	2.5 mA (15.4 V _{DC}) 7.5 mA (30 V _{DC})	15.4 V _{DC} 30 V _{DC}	- 40 to 125° C	8700 psi

Sensor Termination: Flying Leads or M12 Connector

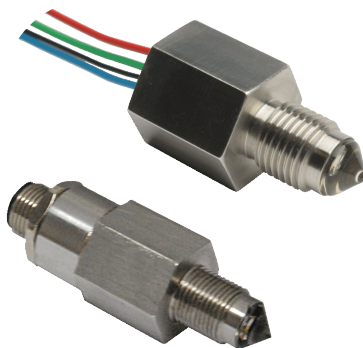

This optical level sensor is compact in size, with a lack of moving parts, and features transient over-voltage and short circuit protection. All while being extremely accurate for point level detection in high-stress environments. Optical liquid sensors operate accurately in any size tank, and are designed with a very robust construction permitting use in a wide variety of demanding applications. As a result, optical sensors are a go-to option for leak detection. The monitoring and prevention of leaks is critical for service interruptions. Protecting equipment is critical to many industries. Optical sensors can be mounted inside or outside of any tank, and are ideal for industrial applications because they are compatible with most fluids and chemicals

Circuit Diagrams

In order to suit any application, these sensors have been designed with various output circuit configurations. They are identified by the code at the end of the part number in the [Product Number Configuration](#) guide.

**N-Type with Flyback
Protection Diode High in Air**

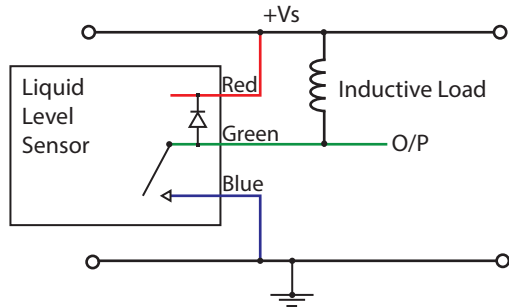

**N-Type with Flyback
Protection Diode Low in Air**

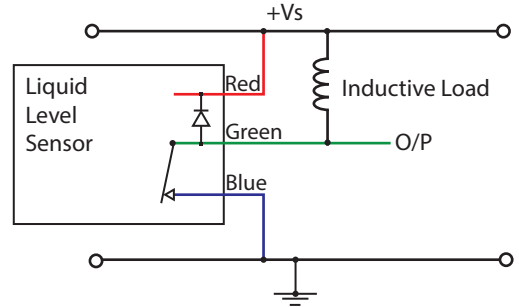

**N-Type with Internal 10kΩ
Pull-Up Resistor High in Air**

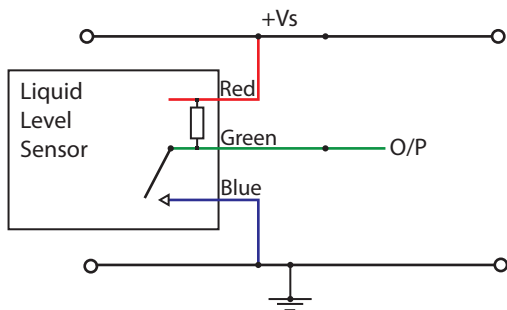

**N-Type with Internal 10kΩ
Pull-Up Resistor Low in Air**

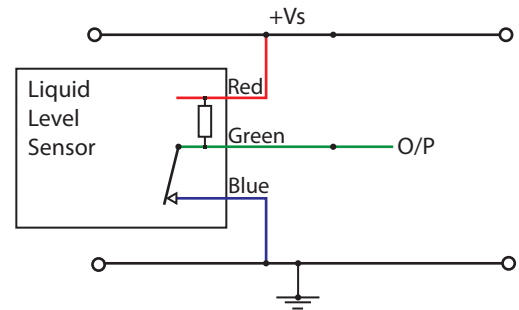

N-Type High in Air

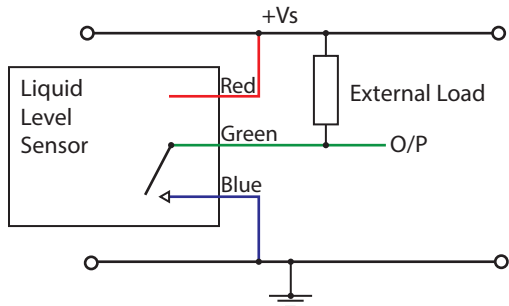

N-Type Low in Air

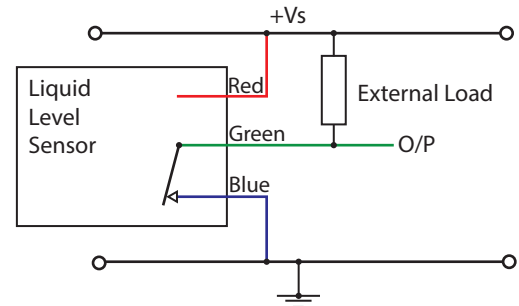

P-Type High in Air

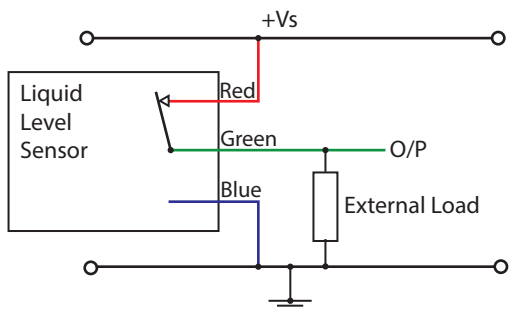

P-Type Low in Air

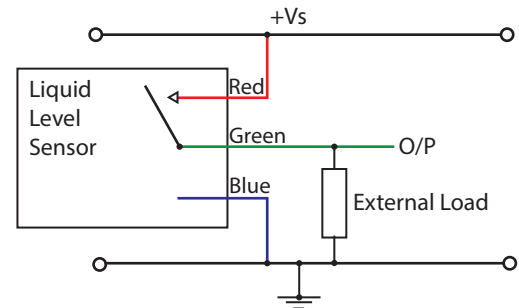

Circuit Diagrams

N&P-Type Push Pull High in Air

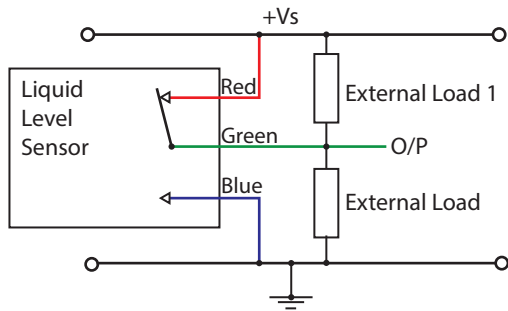

N&P-Type Push Pull Low in Air

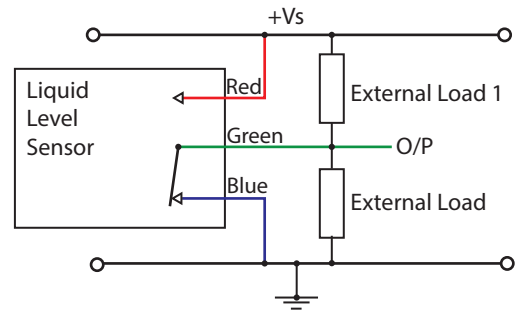

Caution: Take care when connecting loads. The minimum load impedance should not exceed V_s/MAX output current.

Note: Shorting the output to V_s or $0V$ will result in irreparable damage to the sensor.

Mounting

Note: Fixing Nut and O-Ring available; email solutions@fluidswitch.com for details

2 & 6

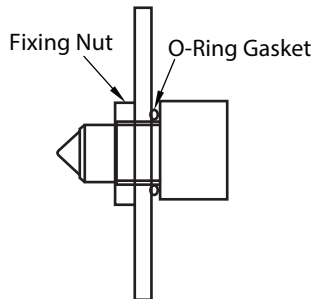

7 & 8

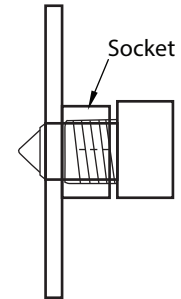

Product Number Configuration

Generate your specific part number using the convention shown opposite. Use only those letters and numbers that correspond to the sensor and output options you require.

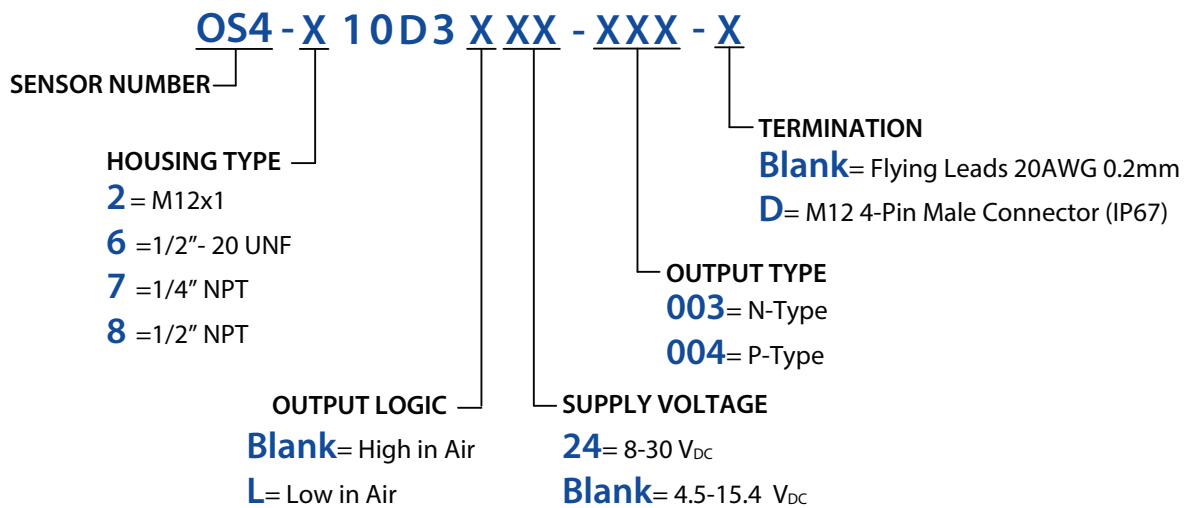

Not suitable for use in freezing liquid or high condensing environments such as steam. Voltages applicable to output value stated. Standard switch dimensions shown; when fitted with M12 connector, the overall length of the switch is 63.3 mm DO NOT over tighten torque as this can permanently damage the switch.